

Model: K3166i

13 Channels (7V + 6I) output. Each output channels are independent control of magnitude, phase angle & frequency values, can generate a variety of output waveforms such as: DC; sinewave; sinewave with percent harmonics at various phase angles etc.

Independent variable battery simulator (DC 15~350V, 140watts)

Anti-clipping detect; cabinet grounding, wrong wiring connect alarm and self-protect, overload and over heat protection.

Test high burden electromechanical relays, 6x10A continuously outputs.

Provide convenient and prompt precision calibration for amplitude and phase by software without open the cabinet.

Light weight & State of art design, 17.5Kg only

Small, lightweight(17.5kg) all in one box solution, with optional IEC61850 SV, IEC61850 GOOSE, energy meter & transducer calibration modules, fully functions KRT software allow advance state sequence, ramping, overcurrent, distance, differential, power swing, synchronizer modules, etc.

IEC61850 GOOSE and SV complying



Graphical test modules and templates for testing of various relays

Quick relay testing facility in Manual mode

Point & Click testing

RIO/XRIO import and export facility

Switch on to fault (SOTF)

Power system model for dynamic testing

GPS sync end-to-end testing

Online vector display

Automatic compare actual characteristic with expected characteristic

Comtrade file generate and playback

Automatic test report creation

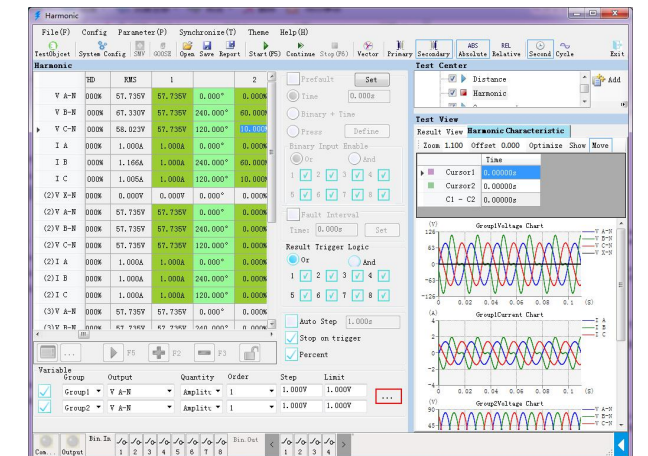
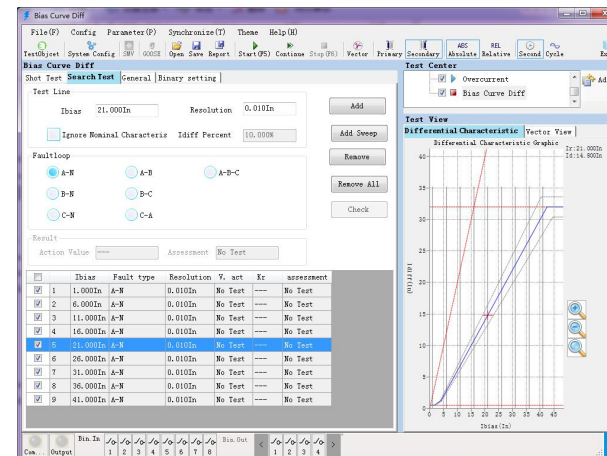
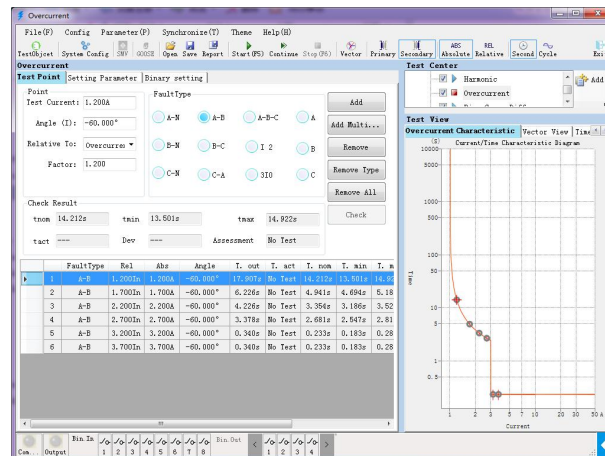
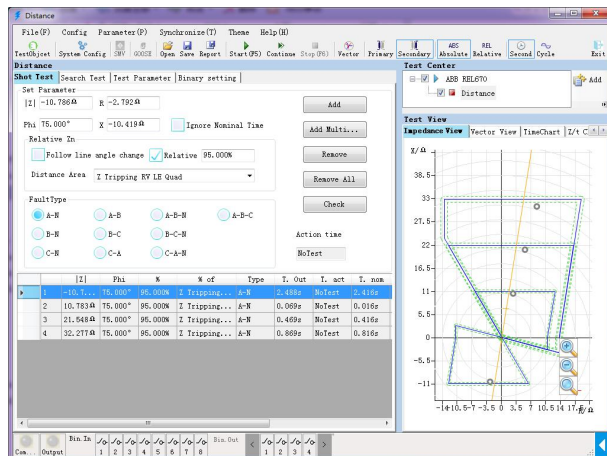

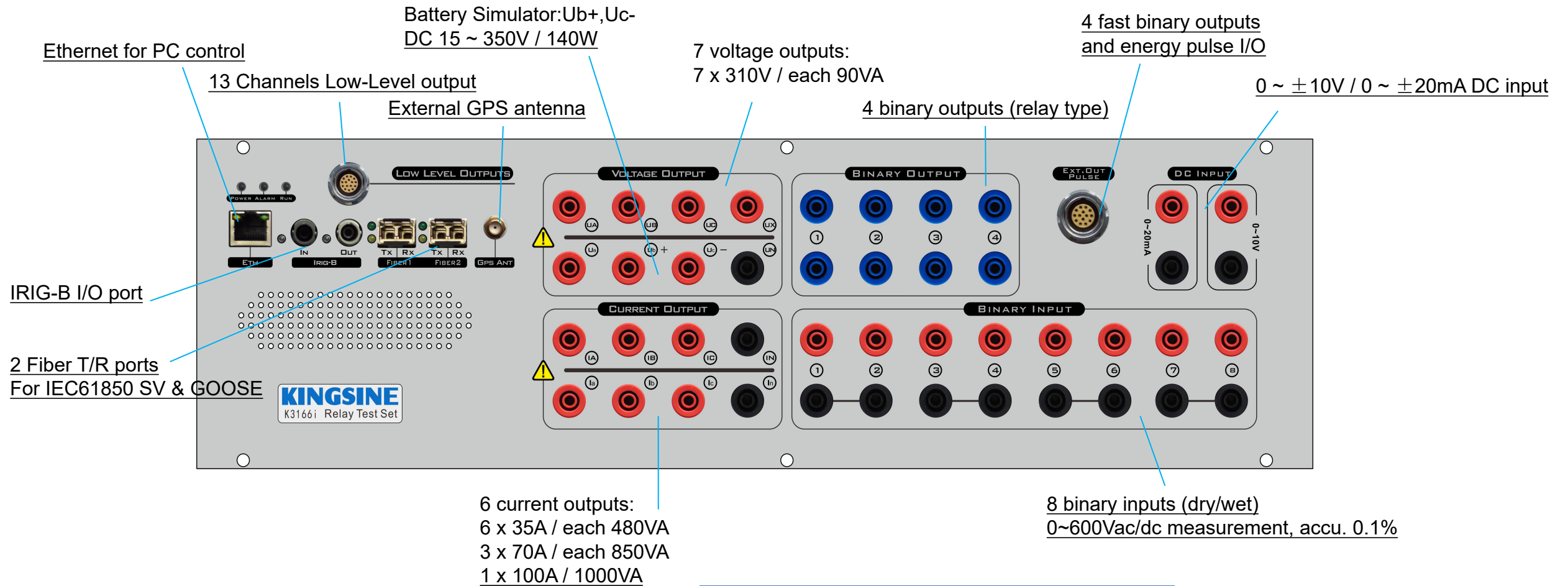

Models reference for selection

Models	Configuration
K3163i	(6 x 35A / 3 x 70A, 4 x 310V)
K3166i	(6 x 35A / 3 x 70A, 7 x 310V)
K3130i	(3 x 35A, 4 x 310V)

8 Pairs Binary Inputs & 4 Pairs Binary Outputs
 DC 0~350V Battery Simulator
 Optional for IEC61850 SV or GOOSE, Energy meter calibration, Transducer calibration, Standard meter, modules

Capable of what K31 series can test

Items	ANSI® No.	Items	ANSI® No.
Distance protection relay	21	DC overcurrent relays	76
Synchronising or synchronism-check relays	25	Phase-angle measuring or out-of-step protection relays	78
Undervoltage relays	27	Automatic reclosing devices	79
Directional Power relays	32	Frequency relays	81
Undercurrent or underpower relays	37	Motor overload protection relays	86
Negative sequence overcurrent relays	46	Differential protection relays	87
Overcurrent/ground fault relays	50	Directional voltage relays	91
Inverse time overcurrent/ground fault relays	51	Voltage and power directional relays	92
Power factor relays	55	Tripping relays	94
Overvoltage relays	59	Voltage regulating relays	
Voltage or current balance relays	60	Overimpedance relays, Z>	
Directional overcurrent relays	67	Underimpedance relays, Z	
Directional ground fault relays	67N	Time-delay relays	



Current Generators	
Current:	AC 6x35A @ 480VA
	AC 3x70A @ 850VA
	AC 1x100A @ 1200VA
	DC 3x20A @ 300W
Current Accuracy	<0.02%rd+0.01%rg,Typ.@ 0.5~35Aac
	<0.05%rd + 0.02%rg,Guar.@ 0.5~35Aac
Range	Range I : 3A; Range II : 35A; Automatic range
Distortion	< 0.025% Typ. / <0.07% Guar.
Voltage Generators	
Voltage:	AC 7x310V L-N @ 90VA Max
	DC 3x350V @ 105W
Voltage Accuracy	<0.015%rd +0.005%rg. Typ.@ 2~310V
	<0.04%rd +0.01%rg. Guar.@ 2~310V
Range	Range I: 30V; Range II: 310V; Automatic range
Distortion	< 0.015% Typ. / <0.05% Guar.
Frequency & Phase angle	
Frequency range:	DC~1KHz, 3KHz transient
Frequency accuracy:	±0.5ppm
Freq. resolution:	0.001Hz
Phase angle:	-360~+360°
Phase accuracy:	<0.02°typ,<0.1°Guar,50/60Hz
Phase resolution:	0.001°
13 Low-level outputs	
Quantity:	13 channels, 16 pin combination socket
Voltage:	AC 0~8Vrms, DC 0~10V
Current:	Rating 2mA, 10mA transient max.
Power:	≥0.5VA
Accuracy	(0.01~0.8 Vrms):<0.05% Typ. / <0.1% Guar.
	(0.8~8 Vrms): <0.02% Typ. / <0.05% Guar.
Resolution:	0.25mV
Distortion (THD%):	< 0.05% Typ. / <0.1% Guar.
Binary outputs (Relay type)	
Quantity:	4 pairs
Type:	Potential free relay contacts, software controlled
Break capacity AC	Vmax:400Vac / Imax:8A / Pmax:2500VA
Break capacity DC	Vmax: 300Vdc / Imax: 5A / Pmax: 150W

Binary outputs (Semiconductor)	
Quantity:	4 pairs semiconductor
Type:	Open-collector, 14 pin combination socket
Break capacity DC	5~15Vdc / 0.1A, 0.5A max
Response time:	<100us
Binary input	
Quantity:	8 pairs
Type:	wet/dry, measurement
Threshold:	0~600Vdc or potential free, Programmable
Sample rate:	10KHz
Time resolution:	10us
Debounce time:	0~25ms (Software Controlled)
Time range:	Infinite
Time errors:	< ±1ms @ 0.001~1s, < ±0.1% @ >1s
Galvanic isolation:	4 isolated with each 2 pairs
Input impedance:	600KΩ
Auxiliary DC (Battery simulator)	
Auxiliary DC:	0~350V @ 140W Max
	0.5% rg Guar.
Others, Size & Weight	
PC connection:	1 x 10/100M Base-Tx RJ45 Ethernet
Synchronizer port:	IRIG-B,GPS SMA Antenna
Others:	RS-232
	14 pin comb. socket for pulse I/O and Bi.output
Size:	468 x 375 x 164 mm
Weight:	<18kg
Power supply & Environment	
Nominal input voltage	100~240Vac
Permissible input	85~264Vac, 125~350Vdc
Nominal frequency	50/60Hz
Permissible frequency	45~65Hz
Power Consumption	1500VA max.
Connection Type	IEC60320 Standard AC socket
Grounding Terminal	4mm banana socket
Temperature	-10°C~55°C (operating), -20°C~70°C(storage)
Humidity	5%-95% RH,non-condensing

Optional Functions

AC/DC Measurement (Optional)	
<i>Voltage range:</i>	0~600Vrms (Rg:0.1V,1V, 10V, 60V, 600V)
<i>Voltage accuracy:</i>	<0.1% rg
<i>Current range:</i>	0~5Arms(clamp input) (0~30A Optional)
<i>Current accuracy:</i>	<0.1% rg
<i>Frequency range:</i>	45~65Hz, Accuracy < 0.01Hz
<i>Phase accuracy:</i>	0~360°, <0.2°Typ
<i>Recorder time:</i>	Max 50 Sec.

Transducer calibration (to be activated)	
DC Current	
<i>Range:</i>	DC: 0~±1mA; 1~±20mA; Auto range
<i>Max. input:</i>	600mA
<i>Input impedance:</i>	15Ω
<i>Accuracy:</i>	<0.05% rg Typ. <0.1% rg Guar.
DC Voltage	
<i>Range:</i>	DC 0~±10V
<i>Max. input:</i>	±11V
<i>Input impedance:</i>	1MΩ
<i>Accuracy:</i>	<0.05% rg Typ. <0.1% rg Guar.

Energy Meter Calibration (to be activated)	
<i>Sensor usage:</i>	Mechanical meters / Electronic meters.
<i>Sensor output:</i>	Highlevel: ≥4.5V,Lowlevel: ≤0.2V.
<i>Pulse input:</i>	1 pulse input ports
<i>Pulse range:</i>	500KHz pulse input max.
<i>Pulse output:</i>	1 transistor outputs
<i>Accuracy:</i>	<0.1% rg Typ. <0.2% rg Guar.

IEC61850 Fiber & GOOSE Ethernet Ports (to be activated)	
<i>Fiber Ports:</i>	2 x 100Base-FX Full Duplex, LC type
	Configurable to 10/100Mbit, Ethernet RJ45 type
<i>Fiber Type:</i>	62.5/125um (Multiple optical fiber, Orange Red)
<i>Wavelength</i>	1310nm
<i>Transmit distance</i>	>1Km
<i>Indicator:</i>	SPD Green (light): valid connection
	Link/Act Yellow (blinking): Data exchanging
<i>NOTE:</i>	All hardware ready for activate

Kingsine Electric Automation Co.,Ltd.

Add: 6C/F4.8 TianAn Cyber Park, Futian,
Shenzhen 518040,China

PH: +86 - 755 - 83418941

FAX: +86 - 755 - 88352611

Email: international@kingsine.com.cn

Website: www.kingsine.com.cn